



Installation and maintenance instructions for AQUAstay tanks



TABLE OF CONTENTS

1	GENERAL INSTRUCTIONS FOR SAFE WORK	3
2	AQUASTAY TANK	3
2.1	TECHNICAL DATA	4
2.2	ADDITIONAL EQUIPMENT OF THE TANK	5
3	UNLOADING OF THE TANK	5
4	INSTALLING THE TANK	6
4.1	EXCAVATION AND PREPARATION OF THE CONSTRUCTION PIT	7
4.2	INSTALLATION AND BACKFILLING OF THE TANK	7
4.3	INSTALLATION OF THE TANK UNDER WALKING SURFACES	8
4.4	INSTALLATION OF THE TANK UNDER TRANSPORT SURFACES	9
4.5	INSTALLATION OF THE TANK IN CASE OF GROUNDWATER	11
4.6	INSTALLATION OF THE TANK IN UNSTABLE SLOPES	12
4.7	INSTALLATION OF THE TANK IN CASE OF INFILLING	13
5	INSTALLATION OF ADDITIONAL EQUIPMENT	13
5.1	INSTALLATION OF CONNECTORS	14
5.2	INSTALLATION OF THE COVER	14
5.3	INSTRUCTIONS FOR THE INSTALLATION OF AN EXTENSION RING OR AN EXTENSION	14
6	MAINTENANCE INSTRUCTIONS	15
7	RECYCLING THE TANK	15

Instructions for the installation of AQUAstay tanks



Thank you for the trust you have placed in us by choosing the AQUAstay tank. AQUAstay tanks allow for an easy and cost-effective installation. Failure to follow the installation instructions may result in life-threatening situations, provoke significant material damage and invalidate the warranty. Instructions in digital form are available at www.aplast.si.

1 GENERAL INSTRUCTIONS FOR SAFE WORK

- The installation and assembly instructions must be strictly followed, as otherwise the warranty will not be valid;
- inspect the tank before installation and verify whether the components correspond with your order;
- the tank should be installed by a company with qualified workers who are familiar with the installation instructions;
- the instructions are attached to the bottom of the lid; remove them together with the bag and clips;
- when carrying out the work, observe the construction regulations and safety instructions that apply to this type of task;
- the cover of the tank should always be placed on the inspection opening;
- the tank should only be installed in prepared construction pits and filled in pursuant to the manufacturer's instructions;
- the choice of the cover model depends on the customer's order;
- only additional elements prescribed and approved by the manufacturer of the tank may be added to the tank.
- The warranty will be void if other elements are installed;
- the temperature of the water in the tank must not exceed 35°C (SIST EN 476: 2011);
- maintenance operations must be carried out when the tank is empty and the electrical components are disconnected;
- we recommend that you visually document all phases of the tank unloading and installation process, since you will need the photographs if you wish to assert your warranty claims;
- if the tank is installed under traffic surfaces, there is a risk of contamination of drinking water and measures must be taken to ensure that the system is completely watertight;
- the tank is intended exclusively for underground installation. **It is prohibited to fill an uninstalled tank with water failing to comply with the instructions set out in point 4.2.** During installation the tank must be filled up to the top (only the top edge of the inspection opening can be visible);
- the images in the installation and maintenance instructions are of a purely illustrative nature.

2 AQUAstay TANK

AQUAstay tanks are manufactured using the rotational moulding process, and are available in three standard versions – L, XL, XXL. The dimensions of the tanks are shown in the table.

The TANKs are:

- intended for the collection of drinking water, rainwater and waste water not containing substances which may affect the properties of polyethylene;
- intended exclusively for underground installation;
- equipped with surfaces for the installation of inlet gaskets up to a diameter of 250 mm on the body of the tank and up to 125 mm on the inspection opening;
- optionally equipped with welded piping connections;
- equipped, as a standard, with a PE protection cover.

2.1 TECHNICAL DATA

Volume	Length (L)	Width (W)	Height (H)	Weight
500 l - L		ø 1,0 m	1,03 m	49 kg
1.000 l - L		ø 1,0 m	1,78 m	76 kg
2.000 l - L	1,50 m	ø 1,4 m	1,73 m	104 kg
2.500 l - L	1,80 m	ø 1,4 m	1,73 m	120 kg
3.000 l - L	2,40 m	ø 1,4 m	1,73 m	133 kg
3.500 l - XL	1,80 m	ø 1,7 m	2,03 m	160 kg
5.000 l - XL	2,45 m	ø 1,7 m	2,03 m	215 kg
6.000 l - XL	2,90 m	ø 1,7 m	2,03 m	256 kg
7.000 l - XL	3,40 m	ø 1,7 m	2,03 m	298 kg
10.000 l - XL	4,94 m	ø 1,7 m	2,03 m	395 kg
8.000 l - XXL	2,60 m	ø 2,3 m	2,66 m	261 kg
10.000 l - XXL	3,10 m	ø 2,3 m	2,66 m	307 kg
12.000 l - XXL	3,60 m	ø 2,3 m	2,66 m	350 kg
16.000 l - XXL	4,80 m	ø 2,3 m	2,66 m	515 kg
18.000 l - XXL	5,30 m	ø 2,3 m	2,66 m	551 kg
20.000 l - XXL	5,80 m	ø 2,3 m	2,66 m	591 kg
26.000 l - XXL	7,50 m	ø 2,3 m	2,66 m	770 kg
28.000 l - XXL	8,00 m	ø 2,3 m	2,66 m	810 kg
30.000 l - XXL	8,50 m	ø 2,3 m	2,66 m	850 kg
36.000 l - XXL	10,30 m	ø 2,3 m	2,66 m	1.027 kg
38.000 l - XXL	10,80 m	ø 2,3 m	2,66 m	1.067 kg
40.000 l - XXL	11,30 m	ø 2,3 m	2,66 m	1.108 kg
46.000 l - XXL	13,00 m	ø 2,3 m	2,66 m	1.285 kg
50.000 l - XXL	13,50 m	ø 2,3 m	2,66 m	1.326 kg

The data in the table are for informational purposes only. The manufacturer reserves the right to change the technical data of the product without prior notice. Any discrepancies between the specified technical data and the actual product data do not constitute a basis for the enforcement of claims.

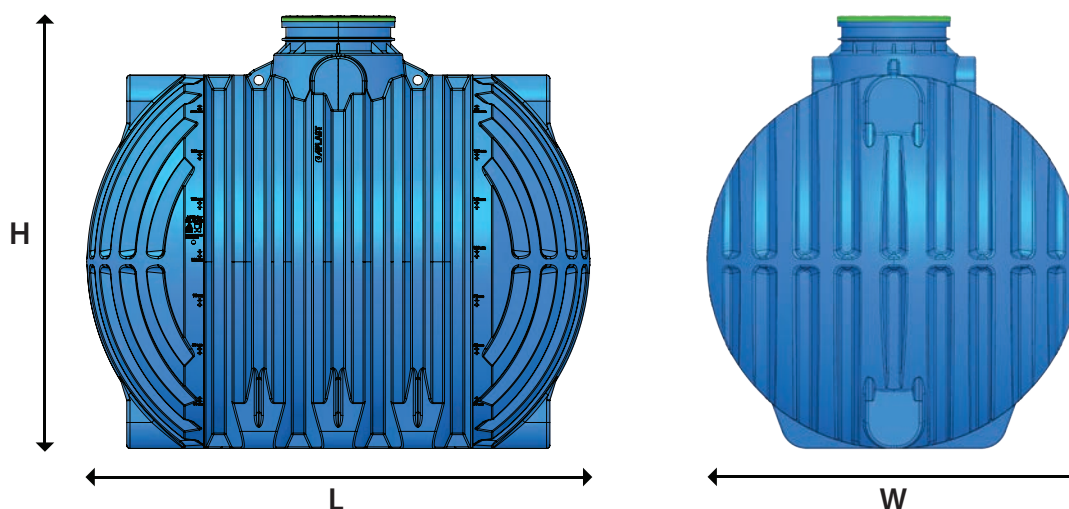

Figure 1: Tank dimensions (H, W and L)

2.2 ADDITIONAL EQUIPMENT OF THE TANK

The tank can be upgraded with additional elements from the Aplast product portfolio:

- It is possible to install a stilling shaft, siphon, filter etc.;
- cover with a lock, cast iron cover, composite cover etc.;
- extension ring or extension;
- quick-assembly couplings;
- inlet gaskets;
- welded pipe connections.

3 UNLOADING OF THE TANK

Pay special attention to the unloading and handling of the tank. The tanks are equipped with lifting eyelets to be used to attach the load slings. Tanks with a volume of over 20,000 l must be unloaded using a console. To ensure the stability of the tank during lifting, each load sling must be weighed down symmetrically, and the appropriate number of slings in proportion to the size of the tank must be provided. It is strictly prohibited to unload tanks with a digger bucket or working machine forks in the middle of the tank, as damage to the tank may occur due to its length and the curving process. Do not push, pull or roll the tank on the ground. Store the tank on a flat and smooth surface.

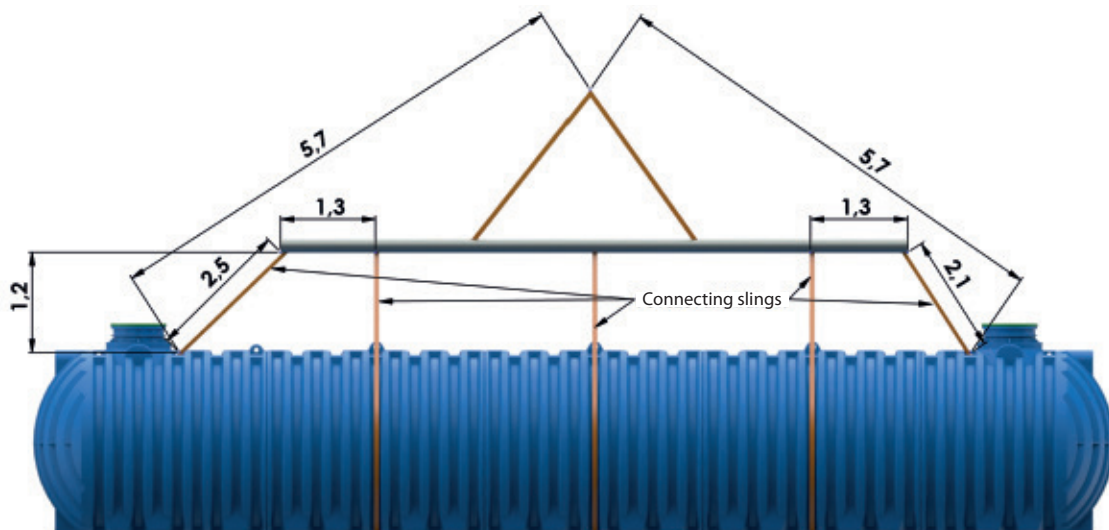
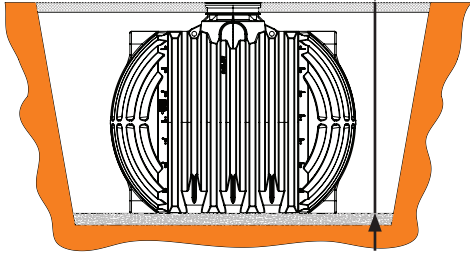
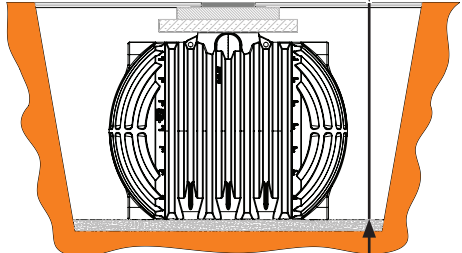
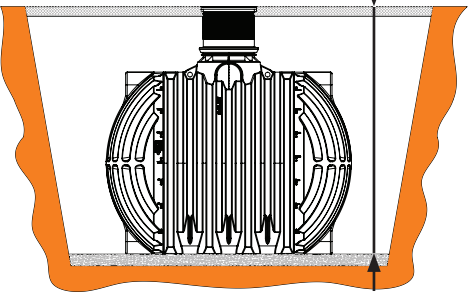
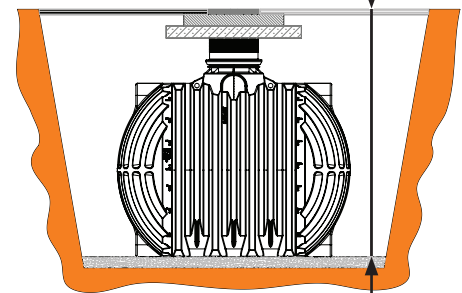

Figure 2: Lifting the tank with console and load slings

4 INSTALLING THE TANK

AQUAstay tanks are designed for underground installation. The tank can be equipped with standard elements, which allows adaptation according to any wishes or needs. The following instructions must be followed:

Installing the tank in walking and transport surfaces (axle load of up to 2.2 tonnes)

	Walking surfaces	Transport surfaces (axle load of up to 2.2 tonnes)
Minimum depth of the installation	H_{\min} L = 173 cm H_{\min} XL = 203 cm H_{\min} XXL = 265 cm 	H_{\min} L = 233 cm H_{\min} XL = 263 cm H_{\min} XXL = 325 cm 
Maximum depth of the installation	H_{\max} L = 220 cm H_{\max} XL = 250 cm H_{\max} XXL = 312 cm 	H_{\max} L = 233 cm H_{\max} XL = 263 cm H_{\max} XXL = 325 cm 

Installing tanks next to one another.

When installing tanks next to one another, it is necessary to consider the distance between them, which should amount to at least 60 cm in all directions.

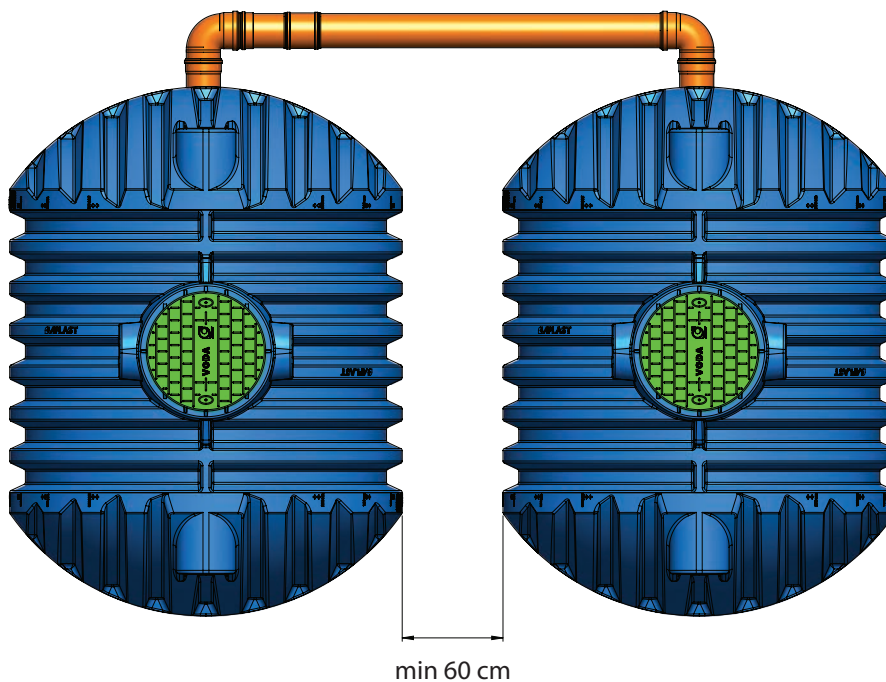

Figure 3: Installing tanks next to one another

4.1 EXCAVATION AND PREPARATION OF THE CONSTRUCTION PIT

Perform the excavation of the construction pit in accordance with Figure 4. The maximum depth of the installation must be consistent with the appropriate thickness of the sand or concrete base and the height of the tank. The construction pit must be at least 60 cm larger than the floor plan of the tank. We recommend the use of geotextile, placed between the soil and the fraction of the backfill material.

The substrate must be solid, compact and flat, made of:

- crushed material containing a mixture of grains ranging in sizes from 0 to 16 mm, or
- round grain material (gravel) containing a mixture of grains ranging in sizes from 0 to 32 mm, or
- concrete slabs.

The appropriate thickness of the base ranges from 20 to 30 cm. The substrate must be compressed to a value of 45 MPa according to Evd.



CRUSHED MATERIAL:
crushed stone fraction mixture ranging from 0 to 16 mm



ROUND GRAIN MATERIAL:
river gravel with fractions ranging from 0 to 32 mm

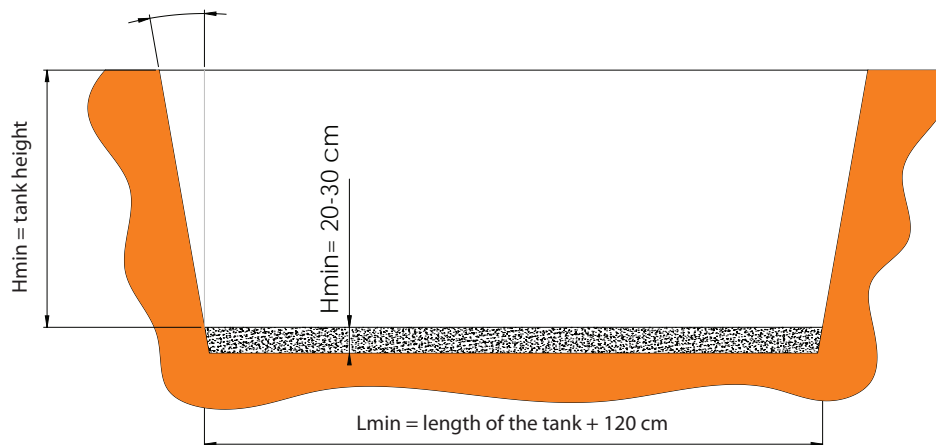

Figure 4: Construction pit

4.2 INSTALLATION AND BACKFILLING OF THE TANK

To backfill the tank, use crushed or round grain material containing a mixture of grain sizes **from 0 to 16 mm (crushed material)** or **from 0 to 32 mm (round grain material)**. When installing the tank, ensure that the weight or operation of the construction machinery does not cause deformation of the product.

The use of backfill material that does not comply with the required specification may damage the tank. **The use of soil, sand or frozen material is prohibited.**

Place the tank in the prepared construction pit. First, pour 30 cm of water into the tank. Then fill the space between the tank and the base using hand-held tools – see Figure 5.

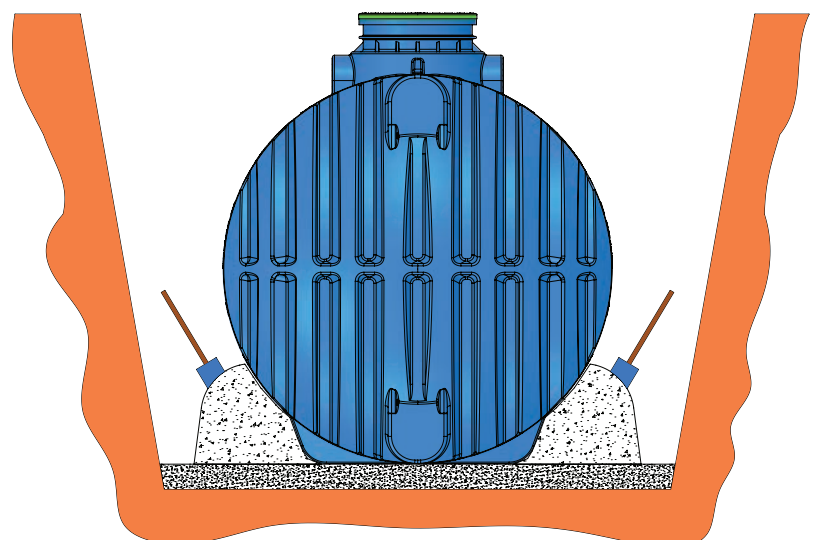

Figure 5: Reinforcing the tank from the side

Continue to backfill and solidify the backfill material around the tank in the height of 30 cm and in the width of 60 cm, until the material reaches the compaction value of 95% pursuant to the Proctor test. Repeat this sequence of tasks by layers of 30 cm until you reach the edge of the inspection opening – see Figure 6.

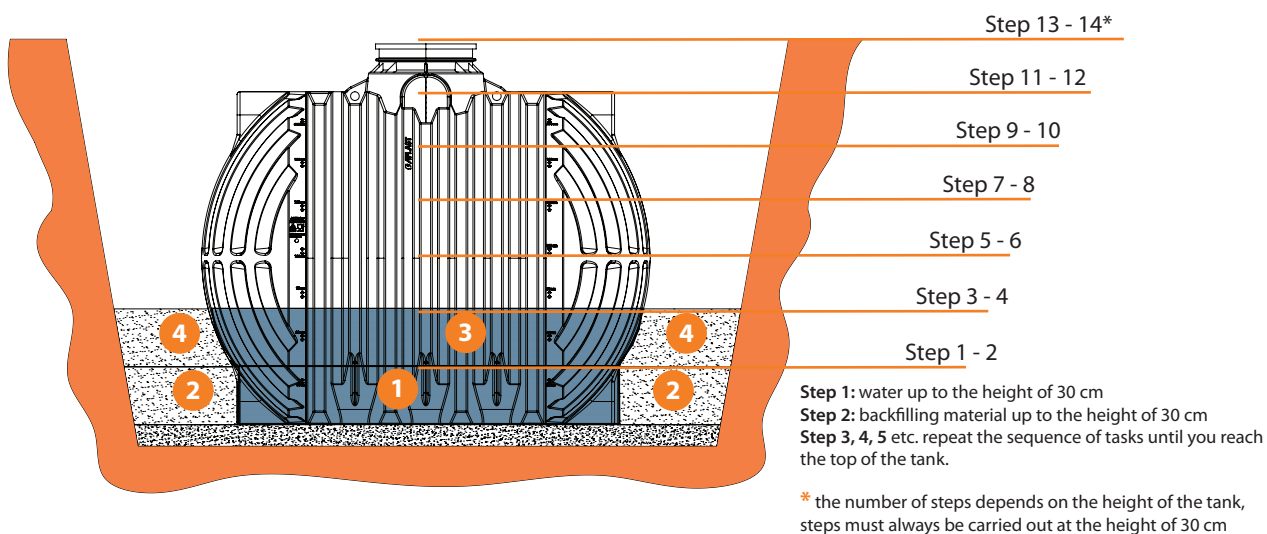

Figure 6: Sequence of tasks to be carried out when backfilling the tank

4.3 INSTALLATION OF THE TANK UNDER WALKING SURFACES

Follow the instructions under 4.1 and 4.2. Perform the basic backfill with the prescribed backfill material at least 10 cm above the top of the tank (Figure 7), then add the final backfill with soil until you reach the edge of the inspection opening.

Recommendation: We recommend the use of geotextiles between the sand layer and the soil layer.

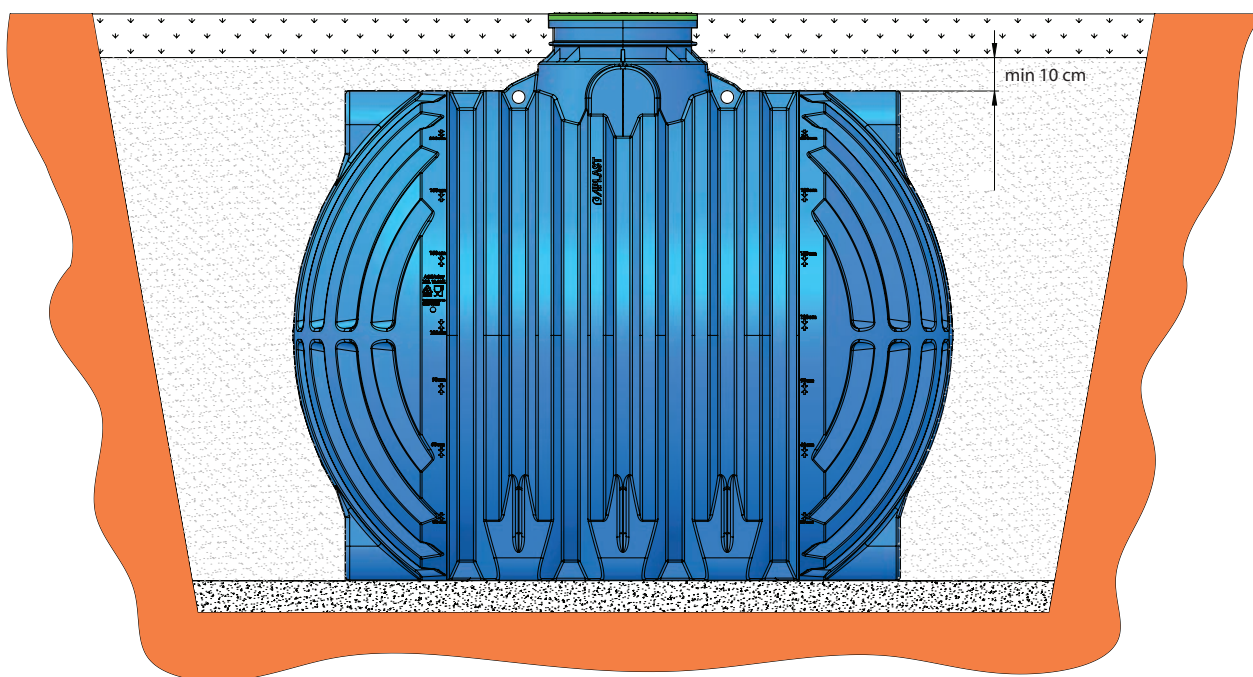

Figure 7: Minimum backfill of the TANK with backfill material before backfilling the last layer of soil

4.4 INSTALLATION OF THE TANK UNDER TRANSPORT SURFACES

Under certain conditions, the AQUAstay tank may be installed under transport surfaces. In addition to following the instructions under 4.1 and 4.2, the following instructions must also be complied with. A cast iron cover or any other cover with a suitable load bearing capacity for the specified area pursuant to standard EN 124-1 must be used for the installation. The cover must be installed in a reinforced concrete ring. The RC ring must be installed on the tank as shown in Figure 8. The RC ring must not rest on the neck of the tank; the distance should amount to no less than 40 mm. The RC ring in combination with the cover represents an effective protection against overloading the tank. Also install a protective PE cover on the tank.

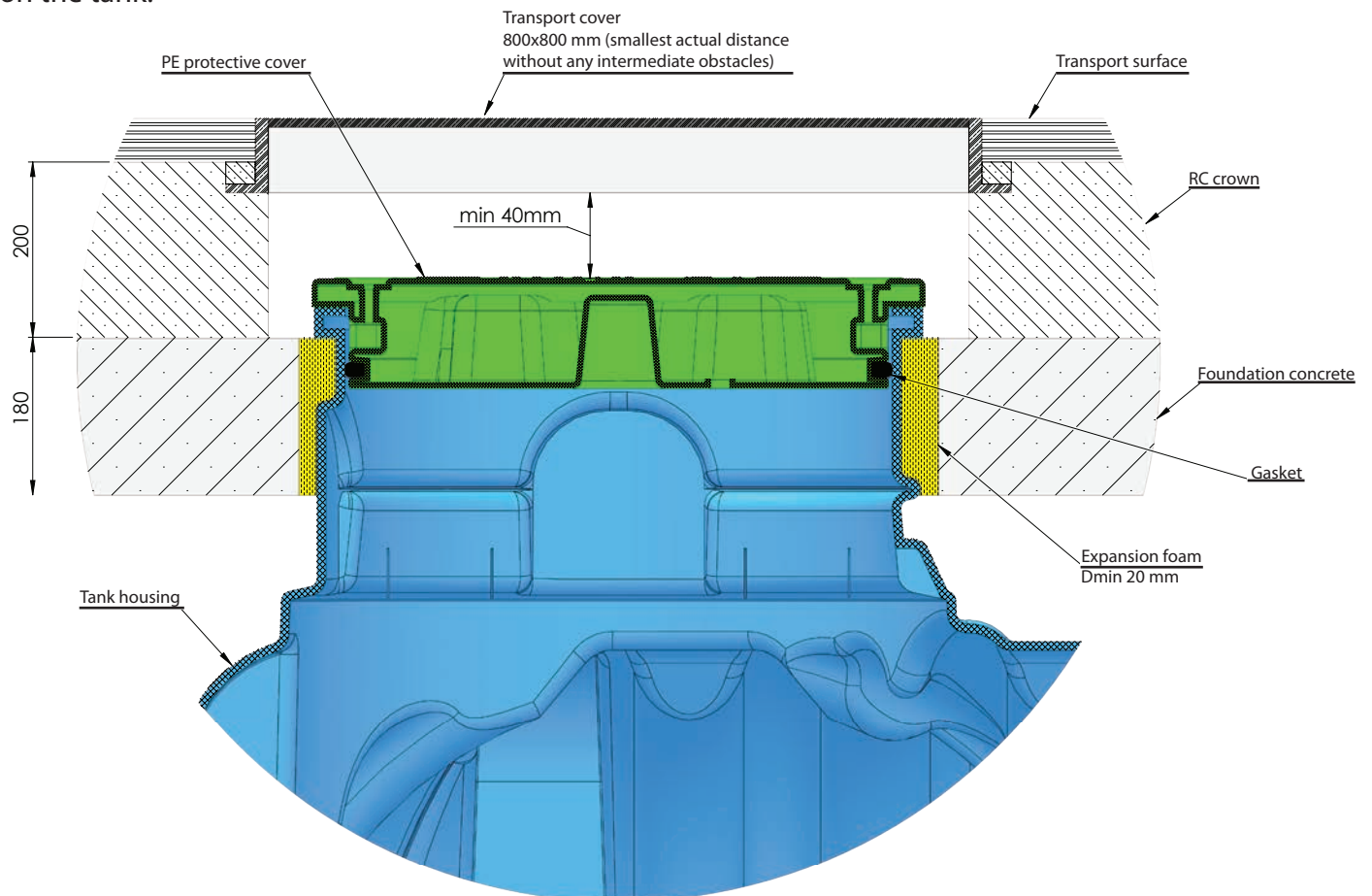

Figure 8: Detail of the installation of the RC ring

Vehicles with an axle load of up to 2.2 tonnes

The tank can be installed under transport surfaces for vehicles, the static axle load of which does not exceed 2.2 tonnes. If you intend to use the tank for this purpose, you must provide an additional backfill layer of 50 cm, which is carried out by installing an additional ring (Chapter 5.3). The installation of the tank is represented by Figure 9.

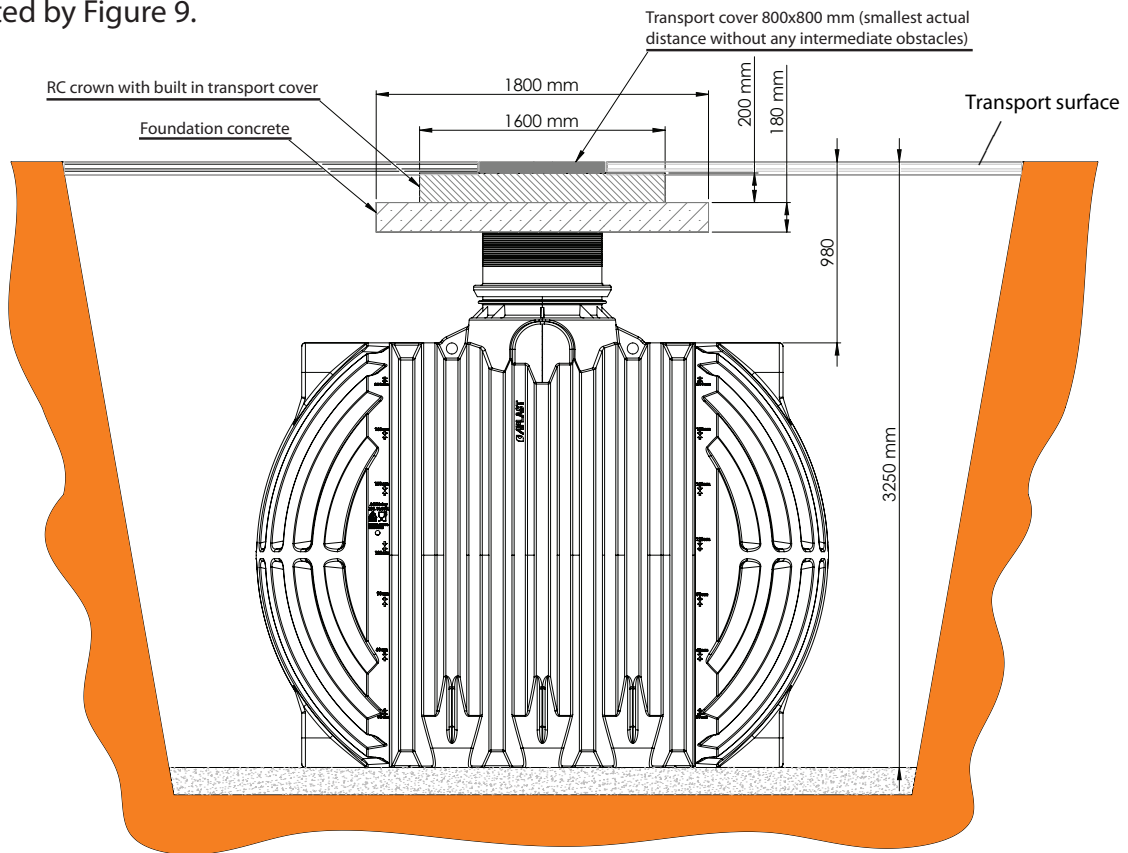

Figure 9: Installation of the tank under transport surfaces for vehicles with an axle load of up to 2.2 tonnes

Vehicles with an axle load of over 2.2 tonnes

When installing the tank under transport surfaces for vehicles, the axle load of which exceeds 2.2 tonnes, an RC plate must be installed above the tank. The tank installed under transport surfaces must be adequately protected, since the tank itself cannot take over the dynamic loads of the road. The static calculation determines the appropriate RC plate, as shown in Figure 10. The execution of the works is determined by the authorised structural designer.

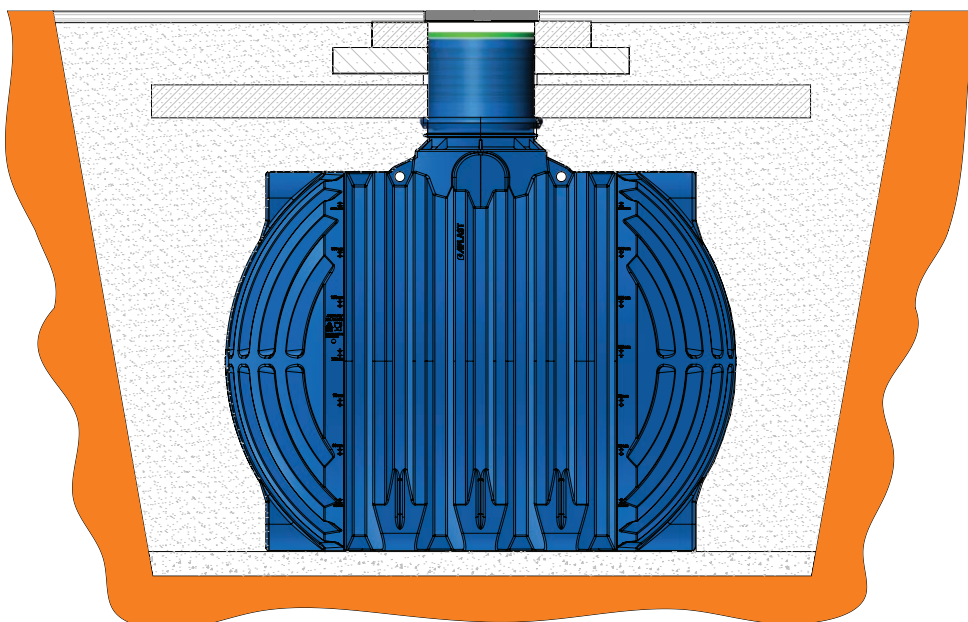

Figure 10: Example of installing a tank under transport surfaces.

4.5 INSTALLATION OF THE TANK IN CASE OF GROUNDWATER



When installing the tank in areas where groundwater is present, it is necessary to take into account its height and install the tank in accordance with the instructions. During construction works or installation of the tank, groundwater must not be present and appropriate measures must be taken to ensure a dry working environment. When preparing the construction pit for the installation of the tank, it is recommended to use and install geotextile between the soil and the backfill material fraction.

The height of groundwater impact on the tank can be up to the maximum height of 115 cm (measured from the bottom of the tank), as shown in Figure 11. In areas where groundwater levels are present or expected to be higher than the permissible level, additional measures should be taken to ensure that the level is maintained. Adequate level of groundwater or other water must be ensured for the entire time of use of the tank.

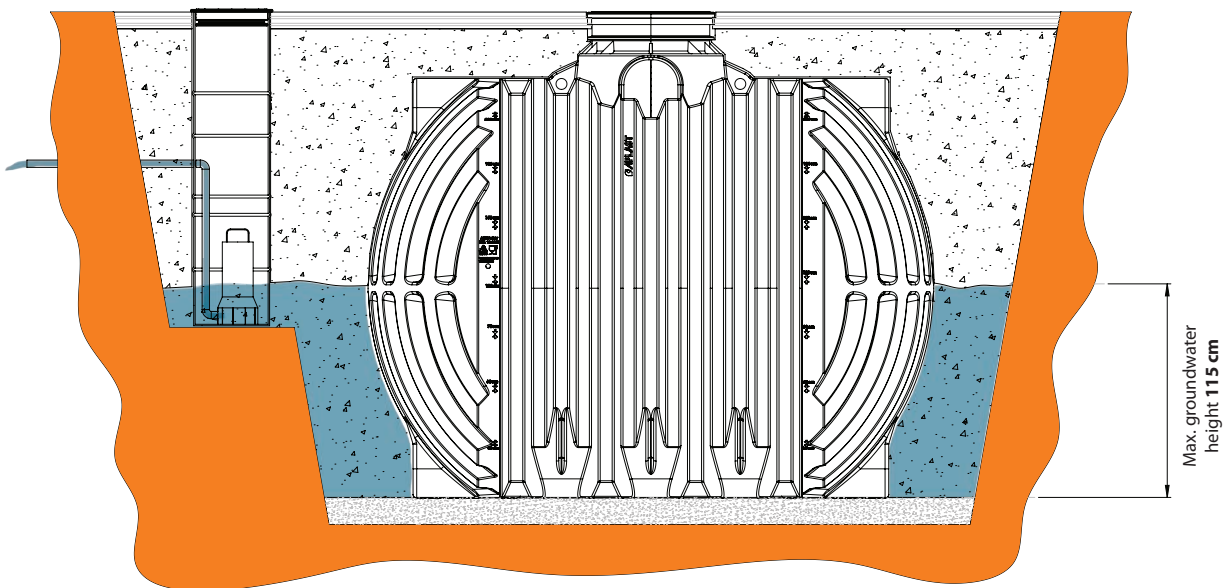

Figure 11: Example of installing a tank in areas where groundwater is present

If the tank is installed in the described areas, the tank must be anchored. For this purpose, use stainless steel strips and attach them to a previously prepared concrete base. The required number of strips is shown in Table 1. The stainless steel strip may wrap around the body of the tank but must not apply any tensile force that would deform the tank.

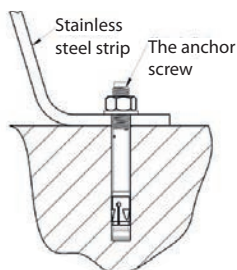

Figure 12: Detail of connection with stainless steel strip



Figure 13: Stainless steel strip for tanks

Tabela 1:

TANK	Strips L - short	Strips L - long	Strips XL - short	Strips XL - long	Strips XXL - short	Strips XXL - long
2.000 I - L		2 pcs				
2.500 I - L		2 pcs				
3.000 I - L	2 pcs					
3.500 I - XL				2 pcs		
5.000 I - XL			2 pcs			
6.000 I - XL			2 pcs			
7.000 I - XL			2 pcs			
10.000 I - XL			3 pcs	2 pcs		
8.000 I - XXL						2 pcs
10.000 I - XXL						2 pcs
12.000 I - XXL					2 pcs	2 pcs
16.000 I - XXL					2 pcs	2 pcs
18.000 I - XXL					2 pcs	2 pcs
20.000 I - XXL					2 pcs	2 pcs
26.000 I - XXL					4 pcs	2 pcs
28.000 I - XXL					4 pcs	2 pcs
30.000 I - XXL					4 pcs	2 pcs
36.000 I - XXL					6 pcs	2 pcs
38.000 I - XXL					6 pcs	2 pcs
40.000 I - XXL					7 pcs	2 pcs
46.000 I - XXL					8 pcs	2 pcs
50.000 I - XXL					10 pcs	2 pcs

4.6 INSTALLATION OF THE TANK IN UNSTABLE SLOPES

If an unstable area is selected for the installation of the AQUAstay tank, it is necessary to ensure that the installation conditions are such that the tank is not affected by ground pressures and landslides. This is ensured using appropriate reinforced concrete (RC) retaining walls – see Figure 14. The dimensions of the retaining wall, the amount of reinforcement and the appropriate drainage are determined by the authorised structural designer.

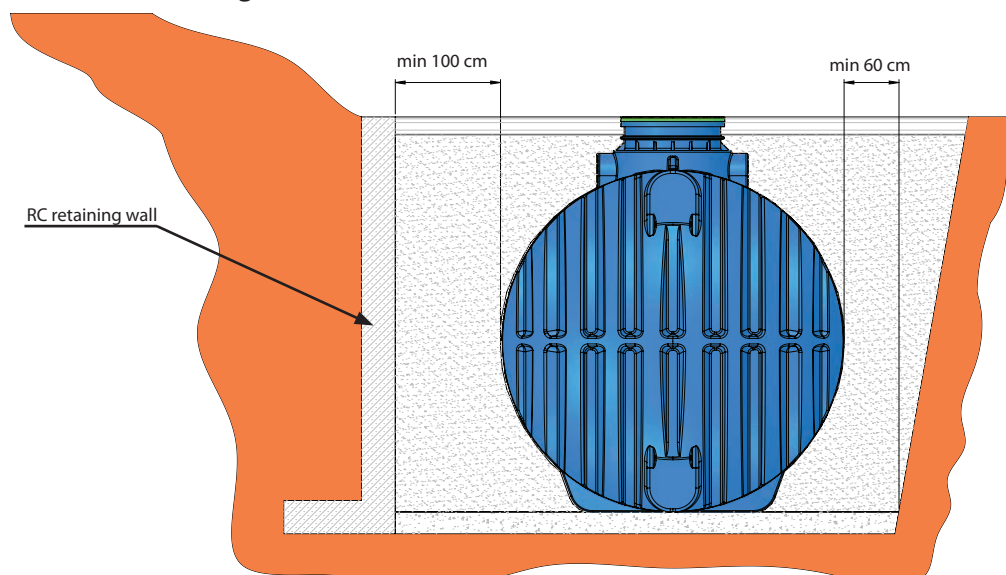

Figure 14: Installation of the tank in unstable slopes

4.7 INSTALLATION OF THE TANK IN CASE OF INFILLING

Up to a permissible increase of 0.5 m

The tank may also be installed deeper, using an additional ring. Also use the ring when the level of backfill material must be adjusted according to the height of the surrounding area. The tank may be raised by 0.5 m (use 1 ring). The installation of the ring must be performed pursuant to Chapter 5.3 of these instructions.

Above the permissible height (more than 0.5 m)

When installing the tank and planning an infill of over 0.5 m over the tank, the tank must be installed with a relief plate. The design of the relief plate and the method of installation shall be provided for by the responsible designer. To raise the tank in this case, use rings with a DN 1000 diameter and an eccentric cover, which is placed eccentrically in relation to the inspection opening of the tank (Figure 15).

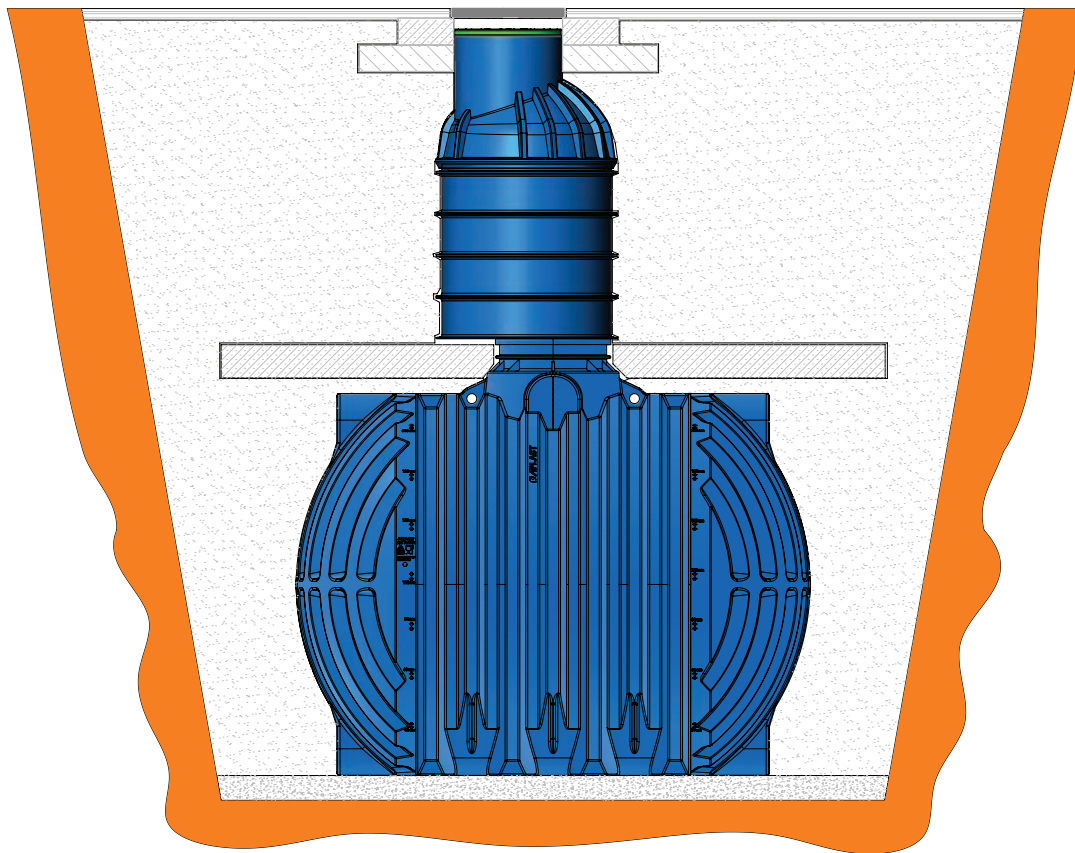

Figure 15: Installation of the tank in case of infilling over the allowed height

5 INSTALLATION OF ADDITIONAL EQUIPMENT

In addition to prefabricated and built-in equipment, AQUAstay tanks can be additionally equipped with standard field elements. For this purpose, it is allowed to use standard connections from APLAST that are compatible with the tank. All inlet pipes and conduits are laid with at least a 1% drop in the direction of current (subsidence must also be taken into account). An overflow pipe shall be installed to prevent any overfilling of the tank. All suction and pressure pipes, as well as all control cables, are routed through a protective pipe. Ensure adequate air supply when using pumps – you can use a vented cover (Figure 17).

5.1 INSTALLATION OF CONNECTORS

All basic tank models have recommended connection points where inlet gaskets can be installed or polyethylene pipes can be welded. The installation of the connections should be carried out by a qualified person.



5.2 INSTALLATION OF THE COVER

The tank has a factory-fitted protective PE cover with a gasket. Clean the cover before each installation and apply a food grade lubricant to the gasket. The cover is optionally available with a lock (Figure 17). In addition, a cover with a vent (Figure 12) is also available as an option.

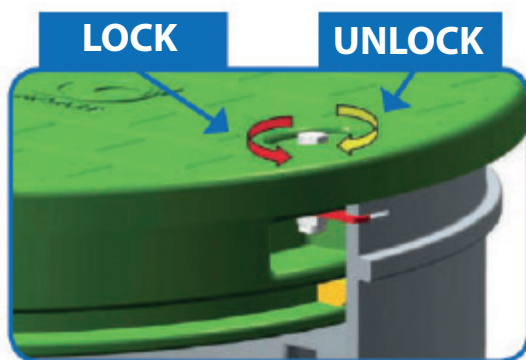

Figure 16: Cover with a built-in lock



Figure 17: Cover with a vent

5.3 INSTRUCTIONS FOR THE INSTALLATION OF AN EXTENSION RING OR AN EXTENSION

In the case of installation of the tank with additional backfill, the tank can be lifted by a maximum of 50 cm using standard extensions or extension rings. Before installing the standard extension, the technological edge of the inspection opening must be removed (Figure 18), after which the tank is ready for the installation of the extension (Figure 19). When installing an extension ring, the technological edge does not need to be removed (Figure 20).

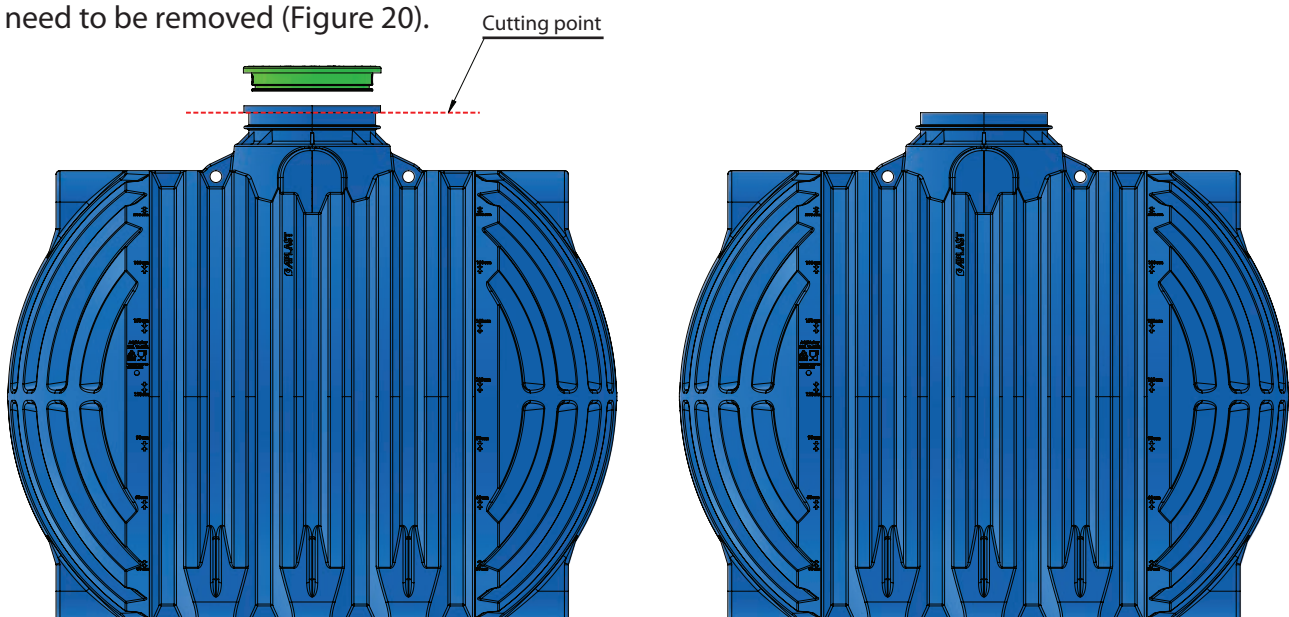

Figure 18: Cutting point of the technological edge

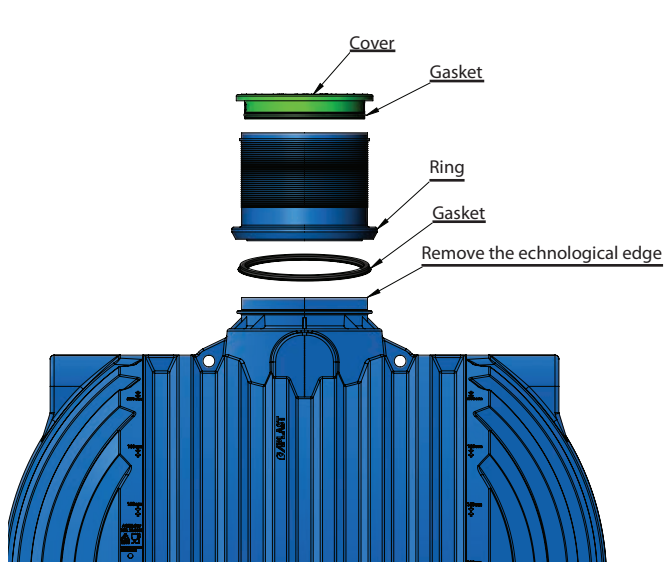

Figure 19: Ring installation option

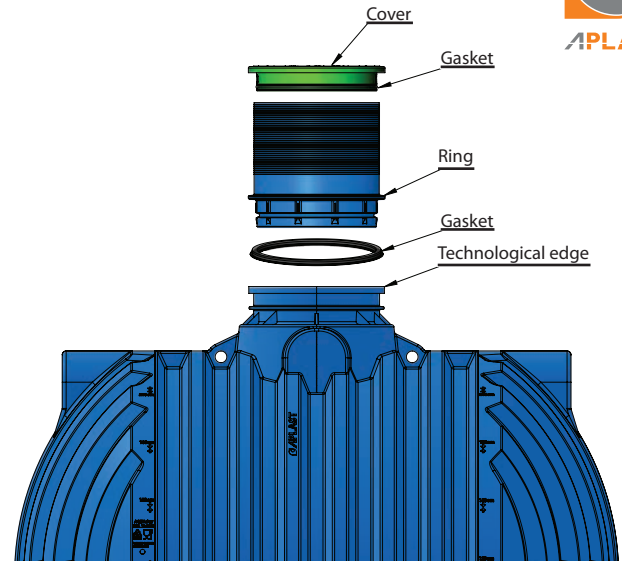

Figure 20: Extension ring installation option

6 MAINTENANCE INSTRUCTIONS

When using the tank, it is necessary to regularly monitor the water level and the possible presence of sludge. We recommend that maintenance work is carried out at least once per year or as required. Maintenance work may only be carried out by a person professionally trained in tank maintenance. Please take note of the following guidelines:

- for safety reasons, at least two persons must be present at the same time;
- ensure a safe working environment and adequate safety and living conditions for the safe performance of maintenance;
- disconnect all electrical sources connected to the tank before carrying out any maintenance work;
- completely empty the tank before cleaning;
- if necessary, clean the inner surfaces of the tank;
- carry out a visual inspection of any possible damage to the inside of the tank. If damage is detected, consult the manufacturer;
- check the pipes, inlet and outlet connections, and installed systems;
- lubricate the cover gasket with food grade grease and install it on the tank. The cover must always be closed;
- wastewater that may adversely affect the properties of polyethylene (e.g. fire water) must be emptied from the tank as soon as possible and treated accordingly.

7 RECYCLING THE TANK

After the end of the service life of the tank, hand it over to an authorised waste management company. The material (the type of material is indicated on the product) may be fully recycled. By reusing the material, you will contribute to the preservation of the natural environment and the reduction of the ecological footprint, as well as to a sustainable approach to resource management.



PE - LD

