

MULTI USE CHAMBERS



Multi use chamber for electro- and telecommunications network is a chamber made of polyethylene (PE), intended electrical cable nodes, fibre optic cables and other cables.

The chambers are available in nominal sizes of DN625, DN800, DN1000, DN1600 and DN 1500.

Advantages of the PE-multi use chamber:

- Long lifespan of the material.
- Watertightness.
- Simple transport.
- Simple manual or machine manipulation.
- Quick and simple installation.
- Quick and simple adjustment of the built-in height.
- Quick and simple construction of connections along the perimeter of the chamber.
- Simple installation of additional connections.
- Installation possible with a PE cover, composite cover or a cast iron cover for the manhole.

Technical data

Material: polyethylene.

Inner chamber diameter: \varnothing 625 mm, \varnothing 800 mm, \varnothing 1000 mm, \varnothing 1600 mm, \varnothing 1500 mm.

Various types of protective pipes:

- PVC- smooth pipes
- PE-smooth and ribbed pipes
- PP-smooth and ribbed pipes

The basic standard connections between FI32 and FI200 are made with inlet gaskets, while nonstandard (larger) connections are made through the process of manual extrusion welding.

EXTENSION TYPE PE-MULTI USE CHAMBER

"Aplast" 1500 x 1500 x 1800



- The upper part of the chamber consists of two layers, and the gap between them is filled with PU foam.
- Due to the additional PE columns and the embedded hot-dip galvanized metal structure, the chamber is reinforced and has a greater loadbearing capacity and chamber body strength.
- Flat surfaces on the body of the chamber enable a simpler installation of additional connections.
- The embedded hot-dip galvanized metal construction enables the installation of leadthroughs for the retraction of electric cables.
- Standing height ensures safe and efficient work.
- Prepared ground plane for PR-cable.

EXTENSION TYPE PE-MULTI USE CHAMBER
 "Aplast" 1500 x 1500 x 1800

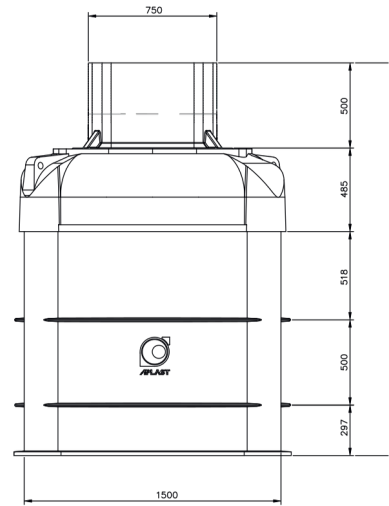

H	IDENT	
1800	217810050	TYPE A – CLASS A (WITHOUT RAISE)
1800	217810100	TYPE B – CLASS D (WITHOUT RAISE)
2300	217810060	TYPE A - CLASS A (COMPLETE)
2300	217810110	TYPE B – CLASS D (COMPLETE)

PE-MULTI USE CHAMBER
 "Aplast" DN 1600/1000

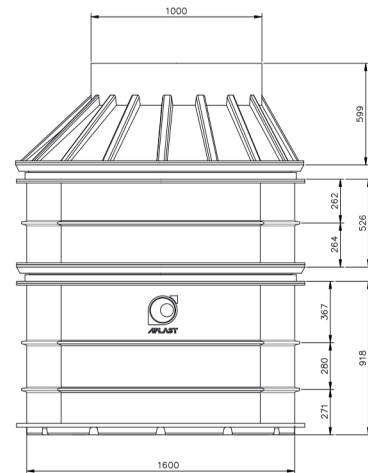

H	IDENT	
1500	217806100	
2000	217806200	

PE-MULTI USE CHAMBER "Aplast" DN 1000/625 EL

PE-MULTI USE CHAMBER "Aplast" DN 1000/625

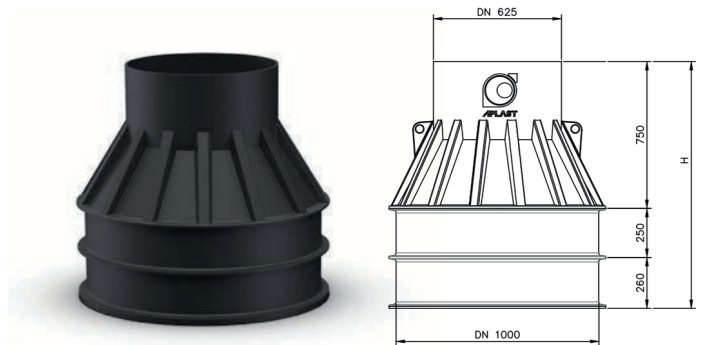
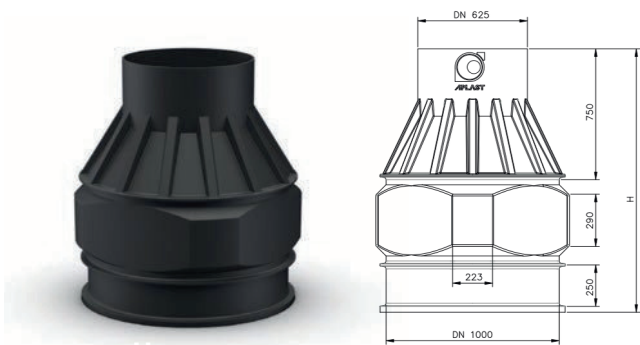

H	IDENT
1250	217804100
1500	217804200

H	IDENT	H	IDENT
750	217803050	1500	217803300
1000	217803100	1750	217803400
1250	217803200	2000	217803500

PE-MULTI USE CHAMBER "Aplast" DN 800/625

PE-MULTI USE CHAMBER "Aplast" DN 625 EL

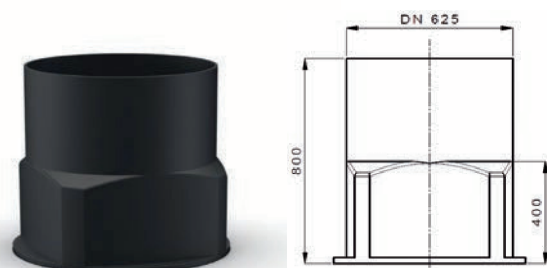

H	IDENT	H	IDENT
750	217801050	1500	217801300
1000	217801100	1750	217801400
1250	217801200	2000	217801500

H	IDENT
500	217800050
800	217800100

Note: Protective covers can be additionally ordered for all types of PE-multi use cable manholes. Available options include covers for walkable surfaces (polyethylene) and drive-over surfaces (composite and cast iron covers).

Essential PE-MULTI USE CHAMBER installation instruction procedures

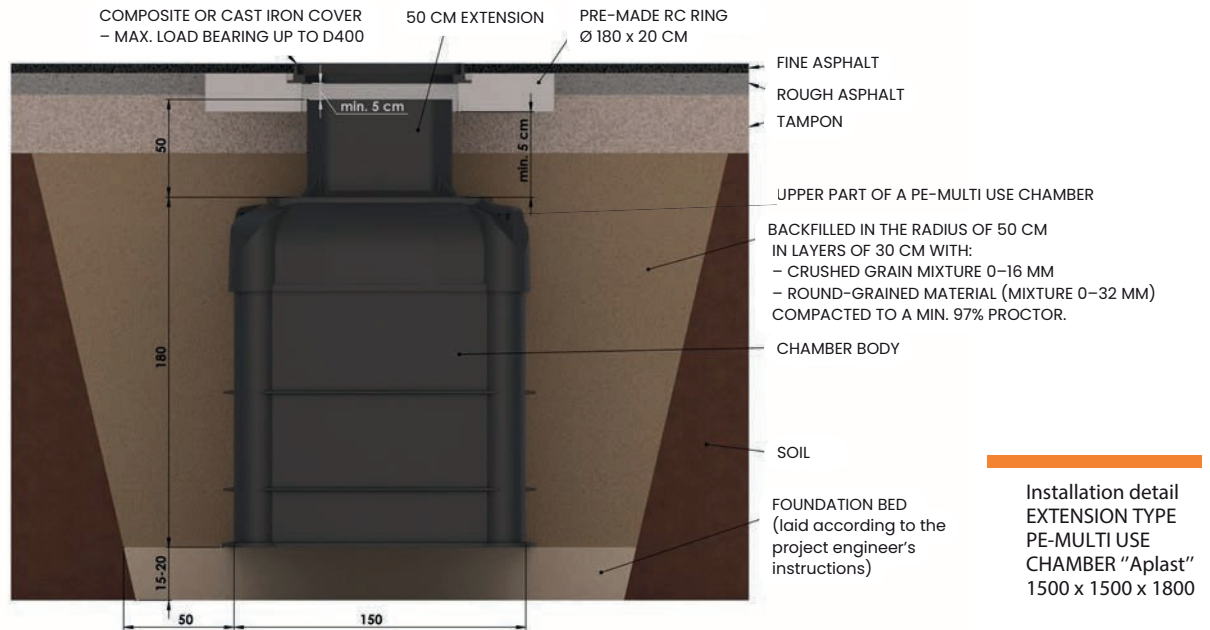

Preparation of the foundations The PE-multi use chamber is placed on a 15-20 cm thick solid and compact bed, appropriately compacted to a min. 97% Proctor. Use suitable materials:

- crushed material - grain size between 0 and 16 mm, round grain material - grain size between 0 and 32 mm.

In the presence of groundwater, the foundation must be made of lean concrete C 12/15, and the shaft must be concreted in the width of 30 cm to the maximum height of the groundwater level.

Backfilling of the shaft

Before backfilling, the inlets and outlets for pipes must be installed.

Backfilling of the PE- multi use chamber requires the use of suitable backfill materials (the same as for the foundations) and the backfilling must be done correctly.

The backfill materials must be compacted carefully and in layers (height up to 30 cm) to a min. 97% Proctor in the radius of at least 50 cm around the chamber body.

MORE DETAILED INSTALLATION INSTRUCTIONS ARE AVAILABLE ON THE WEBSITE www.aplast.si.

Installation of a reinforced concrete (RC) ring with a chamber cover in load bearing surfaces.

When installing the chamber in load bearing surfaces, we must take into account the fact, that the RC ring must not rest on the top of the chamber itself. The distance between the top of the chamber and the cast iron cover must be min. 50mm. Thus, the static and dynamic loads are not directly transferred to the chamber body, but rather to the solid backfill around it.

During the installation process, heavy machinery must not be driven over the chamber or the backfilling area until the installation is complete.



PRESENTATION OF THE PILOT INSTALLATION ON THE ROUTE
ZLATO POLJE-NAKLO NETWORK RTP 110/20-Elektro Gorenjska



1 Preparation of the construction pit.



2 Material filling for the chamber foundation.



3 Installation of the connections to the chamber.

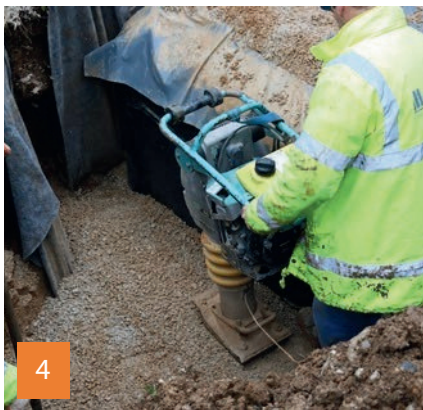

4 Compressing the shaft backfill.



5 Partially backfilled shaft.

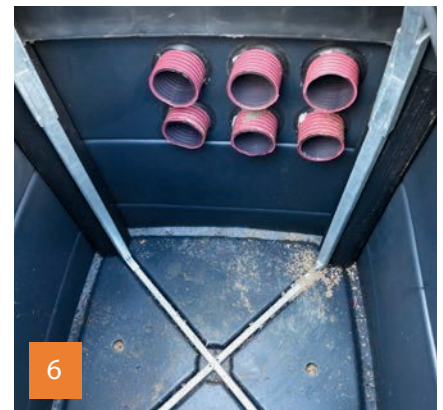

6 Chamber interior with visible drainage holes and installed protective pipes.



7 The chamber grounding process.



8 Preparation and concrete foundation levelling for the RC ring with a cast iron cover.



9 RC ring successfully installed.

Your salesperson:

APLAST
APLAST proizvodnja in trgovina, d. o. o.
Ložnica pri Žalcu 37, 3310 Žalec, Slovenija
www.aplast.si | info@aplast.si



[Empty dotted box for salesperson information]